

CHP. 10 OPTICAL INSTRUMENTS

10.1 LEAST DISTANCE OF DISTINCT VISION:

The normal human eye can focus a sharp image of an object on the eye if the object is located anywhere from infinity to a certain point called the near point.

Def — "The min. distance from the eye at which an object appears to be distinct is called least distance of distinct vision or near point."

It is denoted by 'd'. This distance is about 25 cm from the eye. If the object is held closer than this distance then the eye sees the image blurred and fuzzy. The location of the near point, however, changes with age.

EXPLANATION.

Let an object is placed at the least distance of distinct vision as shown in fig (a). We can see the fine details of the object. But if the object is held closer to the eye than this distance, the image formed will be blurred and fuzzy. In this case the image on the eye would be much larger as shown in fig (b). Now the fine details of the object can be seen by using a convex lens

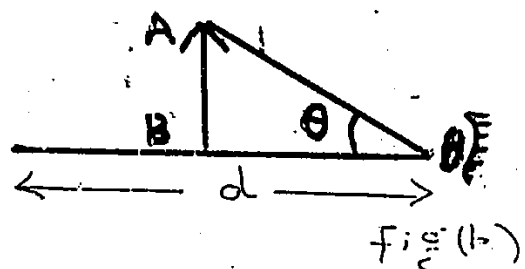
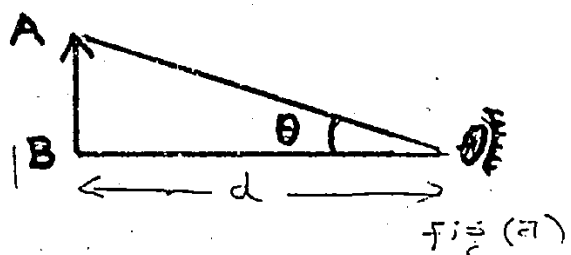

Visit us at
[HTTP://WWW.PHYCITY.COM](http://www.phycity.com)

- Approx. near points of the normal Eye of different ages:

AGE (years)	NEAR POINT (cm)
10	10
20	12
30	15
40	25
50	40
60	100

10.2 MAGNIFYING POWER AND RESOLVING POWER OF OPTICAL INSTRUMENTS.

- The size of the image goes on increasing when we brought an object from infinity to the focal point of a converging lens or a concave mirror - when the size of image goes on increasing then it means that the **magnification** of the object has increased gradually.

MAGNIFICATION.

Def — "The ratio of the size of the image to the size of the object is called magnification." It is also known as linear magnification. i.e;

$$\text{Magnification} = \frac{\text{Size of the image}}{\text{Size of the object}}$$

or, $M = \frac{I}{O}$ ——— (1)

Magnification is also defined as

Def — "The distance of the image from the lens to that of the object from the lens is called magnification."

$$\text{Magnification} = \frac{\text{Distance of the image from the lens}}{\text{Distance of the object from the lens}}$$

or, $M = \frac{q}{p}$ ——— (2)

Comparing eq. (1) and (2), we have

$$L.M = M = \frac{I}{o} = \frac{r}{p} \quad (3)$$

- The apparent size of an object depends on:
 - 1 — Actual size of the object.
 - 2 — Angle subtended by the object at the eye.

Thus, the closer the object is to the eye, the greater is the angle subtended and larger appears the size of the object. fig (a) - A

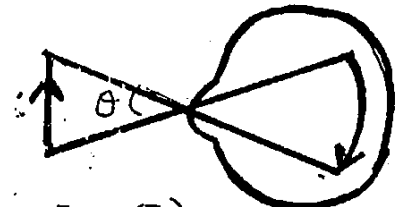

fig (a)

Converging lens allows us to place the object closer to our eye, so that it subtends a large angle.

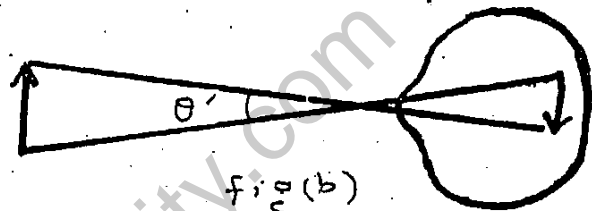

fig (b)

MAGNIFYING POWER OR ANGULAR MAGNIFICATION

Def — "The ratio of the angle subtended by the image as seen through the optical device to that subtended by the object at the unaided eye."

Mathematically,

$$\text{Magnifying power} = A.M = M = \frac{\beta}{\alpha} \quad (4)$$

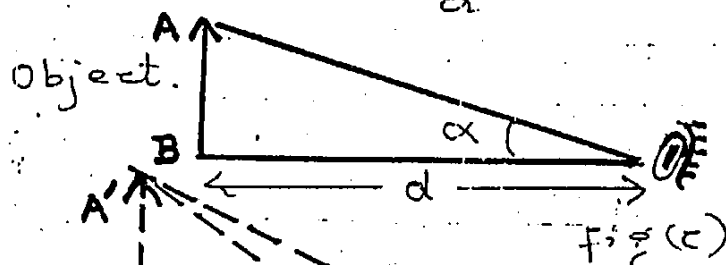
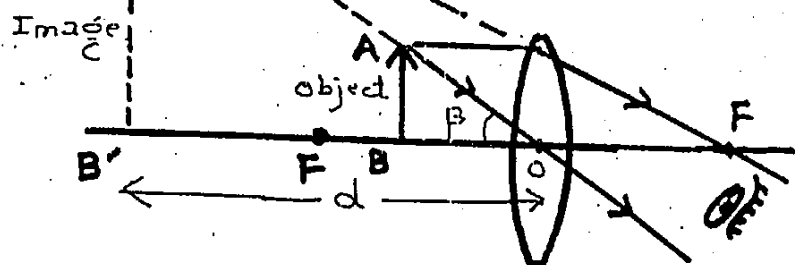

fig (c)

fig (d)



TID BITS

If you find it difficult to read small print, make a pinhole in a piece of paper and hold it in front of your eye close to the page. You will see the print clearly.

RESOLVING POWER.

The diffraction effects are important in the images produced by lenses when we want to distinguish the two closely placed objects. They usually have very small angular separation under these conditions. Therefore the **optical resolution** of microscope or a telescope gives the information to us that how close the two point sources of light are, so we want to see them separately.

If two point sources are too close, they will appear as one because the optical instrument makes a point source look like a small disc or spot of light with circular diffraction fringes.

Although the magnification can be made as large as one desires by choosing appropriate focal lengths, but the magnification alone is of no use unless we can see the details of the object distinctly.

Def. — "The resolving power of an instrument is its ability to reveal the minor details of the object under examination."
or, "The ability of a certain instrument, such as a lens of a microscope to separate two close objects is called the resolving power of the instrument."

It is expressed as α_{\min}

i.e; The min. angle between two point sources that allow the images to be resolved as two distinct spots of light rather than one.

Raleigh showed that for light of wavelength ' λ ' through a lens of diameter ' D ', the resolving power is given by

$$\alpha_{\min} = 1.22 \frac{\lambda}{D} \quad \text{--- (4)}$$

For grating spectrometer |

In the case of a grating spectrometer, the resolving power ' R ' of the grating is;

$$R = \frac{\lambda}{\lambda_2 - \lambda_1} = \frac{\lambda}{\Delta\lambda} \quad \text{--- (5)}$$

where $\lambda \approx \lambda_1 \approx \lambda_2$ and $\Delta\lambda = \lambda_2 - \lambda_1$

Therefore, grating with higher resolving power can distinguish small difference in the wavelengths.

If ' N ' is the number of rulings on the grating, it can be shown that the resolving power in the m th order diffraction equals the product $N \times m$

i.e;

$$R = N \times m \quad \text{--- (6)}$$

• MICROSCOPE :

Def — "An optical instrument which is used for viewing a magnifying image of a near and small objects is called microscope."

10.3 SIMPLE MICROSCOPE :

Def — "A convex lens used to magnify the image when the object is held closer than the near point (i.e; 25 cm) from the eye is called magnifying glass or simple microscope."

EXAMPLE.

A watch maker uses convex lens to mend the watches. The object is placed inside the focal point of the lens. The magnified and virtual image is formed at least distance of distinct vision 'd' or much farther from the lens.

MAGNIFYING POWER.

The image formed by the object, when placed at a distance 'd', on the eye is shown in fig (a).

In fig (b), a lens is placed just in front of the eye and the object is placed in front of the lens in such a way

that a virtual image of the object is formed at a distance 'd' from the eye. The size of the image is now much larger than without the lens.

The angular magnification or magnifying power is given by ;

$$M = \frac{\beta}{\alpha} \quad \text{--- (1)}$$

When angles are small, then they are nearly equal to their tangents.

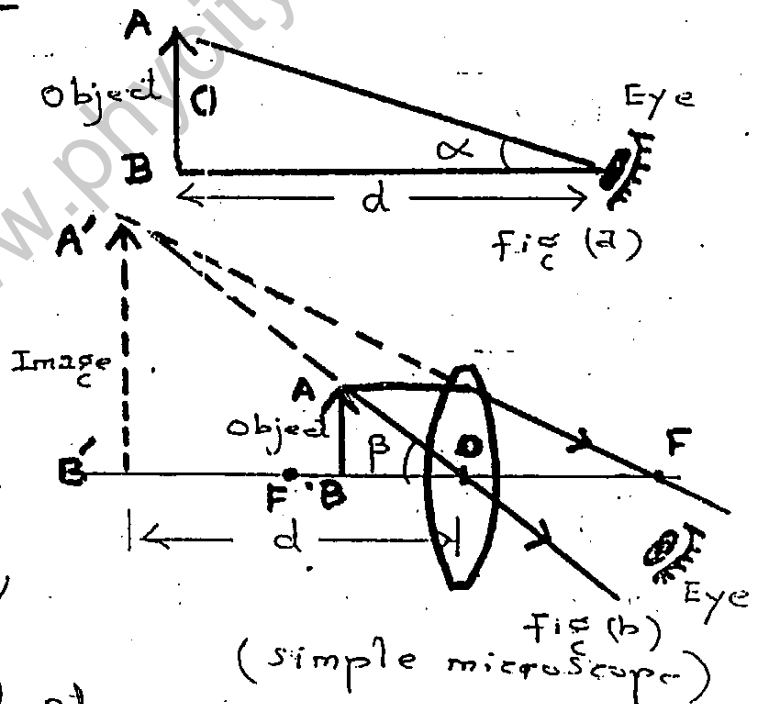

From fig (a) and (b), we find

$$\alpha = \tan \alpha = \frac{\text{size of the object}}{\text{distance of the object}} = \frac{o}{d} \quad \text{--- (2)}$$

and

$$\beta = \tan \beta = \frac{\text{size of the image}}{\text{distance of the image}} = \frac{I}{q} \quad \text{--- (3)}$$

Since the image is at the least distance of distinct vision, hence,

$$q = d$$

Therefore, eq. (3) becomes;

$$\beta = \frac{I}{q} = \frac{I}{d} \quad \text{--- (4)}$$

Putting values of eq. (2) and (4) in eq. (1), we have

$$M = \frac{\beta}{\alpha} = \frac{I/d}{o/d} = \frac{I}{o} \quad \text{--- (5)}$$

As we already know that

$$\frac{I}{o} = \frac{\text{size of image}}{\text{size of object}} = \frac{\text{Distance of the image}}{\text{distance of the object}} = \frac{q}{p}$$

$$\therefore M = \frac{q}{p} = \frac{d}{p} \quad \text{--- (6)}$$

For virtual image, the lens formula is written as

$$\frac{1}{f} = \frac{1}{p} - \frac{1}{q}$$

$$\text{But } q = d$$

$$\text{Hence } \frac{1}{f} = \frac{1}{p} - \frac{1}{d}$$

Multiplying on both sides by d , we get

$$d/f = \frac{d}{p} - 1$$

$$\text{or, } \frac{d}{p} = 1 + \frac{d}{f} \quad \text{--- (7)}$$

Comparing eq. (6) and (7), we have

$$M = 1 + \frac{d}{f}$$

i.e; Magnifying power of a simple microscope or magnifying glass depends upon its focal length.

For higher angular magnification, the focal length should be small.

FOR EXAMPLE. If we have $f = 5 \text{ cm}$ and $d = 25 \text{ cm}$

$$\text{then } M = 1 + \frac{d}{f} = 1 + \frac{25}{5} = \boxed{6}$$

The object would look six times larger when viewed through such a lens.

10.4 COMPOUND MICROSCOPE :

Def — "It is an optical instrument used to see a highly magnified image of a small object is called compound microscope."

CONSTRUCTION.

It consists of two double convex lenses. The lens towards the object is called the objective and of very short focal length and the other lens towards the eye called the eyepiece of relatively larger focal length.

DIAGRAM.

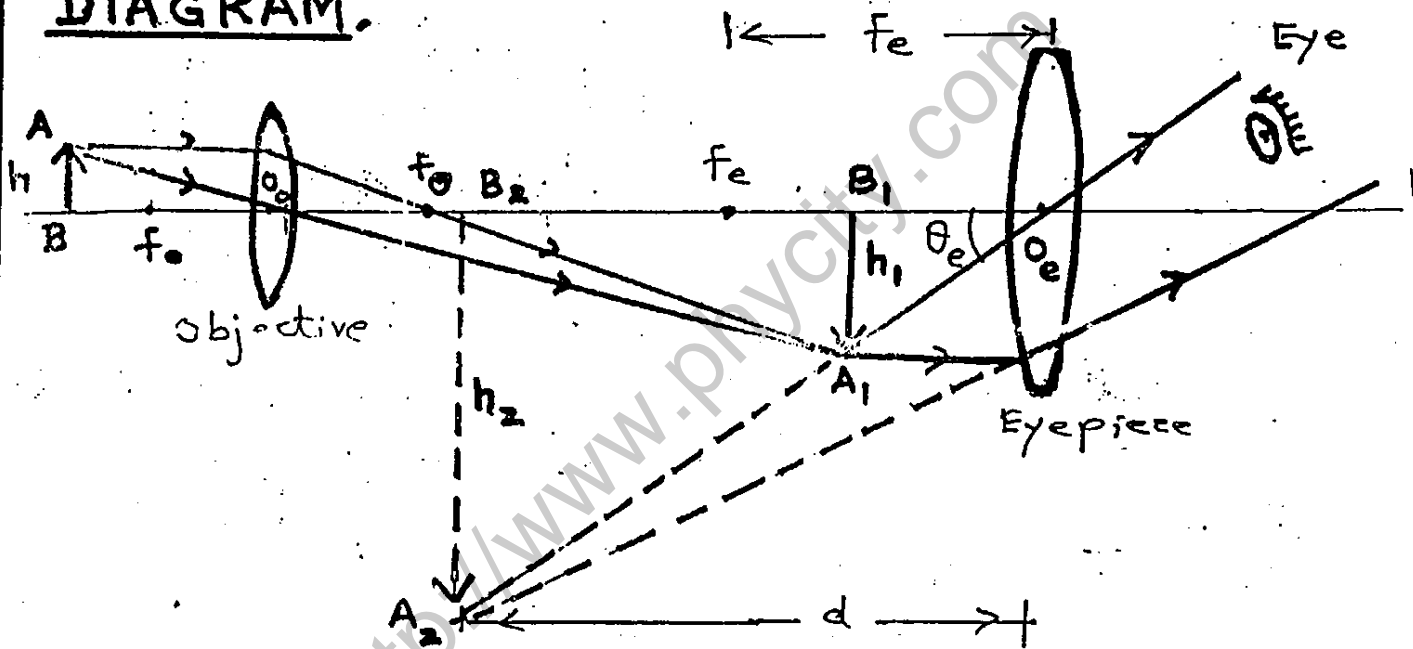

Fig. (A compound microscope)

WORKING.

Suppose an object of height " h " is placed just beyond the principal focus of the objective. The object lens forms a real, inverted and magnified image of height " h_1 " at a place situated within the focal point of the eyepiece. It is then further magnified by the eyepiece which serves as a magnifying glass. The final image seen by the eye through the eyepiece is virtual and very much enlarged.

MAGNIFYING POWER.

The angular magnification of the compound microscope is :

$$M = \frac{\tan \theta_e}{\tan \theta} \quad \text{--- (1)}$$

Where θ_e = Angle subtended by the final image of height h_2 .

and θ = Angle that object of height h subtend at the eye if placed at the near point d .

From fig.

$$\tan \theta = \frac{h}{d} \quad \text{and} \quad \tan \theta_e = \frac{h_2}{d}$$

$$\therefore M = \frac{h_2/d}{h/d} = \frac{h_2}{h} \quad \text{--- (2)}$$

$$\text{or, } M = \frac{h_1}{h} \times \frac{h_2}{h_1} \quad \text{--- (3)}$$

Where ratio h_1/h is the linear magnification M_1 of the objective and h_2/h_1 is the linear magnification M_2 of the eyepiece used as magnifying glass. So total magnification is

$$M = M_1 \times M_2 \quad \text{--- (4)}$$

$$\text{As } M_1 = \frac{q}{p} \quad \text{and} \quad M_2 = 1 + \frac{d}{f_e}$$

$$\text{Hence, } \boxed{M = \frac{q}{p} \left(1 + \frac{d}{f_e} \right)} \quad \text{--- (5)}$$

It is clear that for high magnification, the objective and eyepiece should be of short focal length. However, focal length of objective should be smaller than focal length of eyepiece.

NOTE.

It is customary to refer the values of M as multiples of 5, 10, 40 etc; and are marked as $\times 5$, $\times 10$, $\times 40$, etc; is written on the instrument.

It is actually the limit to which a microscope can be used to resolve the details, depending

(P.T.=)

on the width of the objective. A wider objective and use of blue light of short wavelength produces less diffraction and allows more details to be seen.

EXAMPLE 10.1

A microscope has an objective lens of 10 mm focal length, and an eyepiece of 25.0 mm focal length. What is the distance between the lenses and its magnification, if the object is in sharp focus when it is 10.5 mm from the objective?

- DATA: Focal length of objective = $f_o = 10 \text{ mm}$
 Focal length of eyepiece = $f_e = 25 \text{ mm}$
 Distance of object from objective = $p = 10.5 \text{ mm}$
 Distance between lenses = $L = p + q = ?$
 Magnification = $M = ?$

Sol. If we consider the objective alone

$$\frac{1}{f_o} = \frac{1}{p} + \frac{1}{q} \text{ --- (1)}$$

Putting values, we have;

$$\frac{1}{10} = \frac{1}{10.5} + \frac{1}{q}$$

$$\frac{1}{q} = \frac{1}{10} - \frac{1}{10.5} = \frac{10.5 - 10}{105} = \frac{0.5}{105}$$

$$q = \frac{105}{0.5} = 210 \text{ mm} \text{ --- (2)}$$

If we consider the eye-piece alone with the virtual image at the least distance of distinct vision $d = -25 \text{ cm} = -250 \text{ mm}$.

$$\frac{1}{f_e} = \frac{1}{p} + \frac{1}{q} \text{ --- (3)}$$

As $q = d = -250 \text{ mm}$

putting the values, we have;

$$\frac{1}{25} = \frac{1}{p} - \frac{1}{250}$$

$$\frac{1}{p} = \frac{1}{25} + \frac{1}{250} = \frac{250 + 25}{6250} = \frac{275}{6250}$$

$$p = \frac{6250}{275} = 22.7 \text{ mm} \text{ --- (4)}$$

Distance b/w lenses = $L = q + p = 210 + 22.7 \approx 233 \text{ mm}$

Magnification by objective ,

$$M_1 = \frac{q}{p} = \frac{210 \text{ mm}}{10.5 \text{ mm}} = 20 \quad \text{--- (5)}$$

Magnification by eye-piece ,

$$M_2 = \frac{q}{p} = \frac{-250 \text{ mm}}{22.7 \text{ mm}} = -11 \quad \text{--- (6)}$$

Total magnification is given by ;

$$M = M_1 \times M_2$$

$$M = 20 \times (-11) = \boxed{-220}$$

Negative sign indicates that the image is virtual.

TELESCOPE :

Def — "An optical instrument used for viewing distant objects is known as telescope."

The image of a distant object viewed through a telescope appears larger because it subtends a bigger visual angle than when viewed with the naked eye.

10.5 ASTRONOMICAL TELESCOPE :

Def — "An optical instrument used to see the heavenly objects like moon, stars etc is called astronomical telescope."

CONSTRUCTION.

It consists of two double convex lenses. The one towards the object is called the objective and the other towards the eye is called eye-piece. The focal length of the objective f_o is greater than that of the eyepiece f_e .

DIAGRAM.

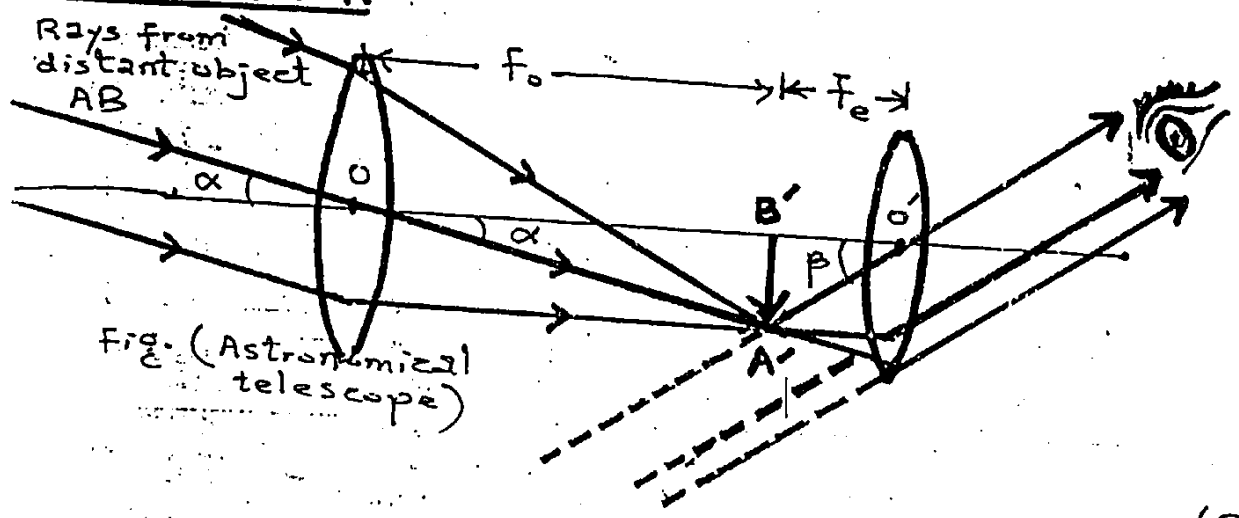

Magnification by objective,

$$M_1 = \frac{q}{p} = \frac{210 \text{ mm}}{10.5 \text{ mm}} = 20 \quad \text{--- (5)}$$

Magnification by eye-piece,

$$M_2 = \frac{q}{p} = \frac{-250 \text{ mm}}{22.7 \text{ mm}} = -11 \quad \text{--- (C)}$$

Total magnification is given by;

$$M = M_1 \times M_2$$

$$M = 20 \times (-11) = \boxed{-220}$$

Negative sign indicates that the image is virtual.

TELESCOPE:

Def — "An optical instrument used for viewing distant objects is known as telescope."

The image of a distant object viewed through a telescope appears larger because it subtends a bigger visual angle than when viewed with the naked eye.

10.5 ASTRONOMICAL TELESCOPE:

Def — "An optical instrument used to see the heavenly objects like moon, stars etc is called astronomical telescope."

CONSTRUCTION.

It consists of two double convex lenses. The one towards the object is called the objective and the other towards the eye is called eye-piece. The focal length of the objective f_o is greater than that of the eyepiece f_e .

DIAGRAM.

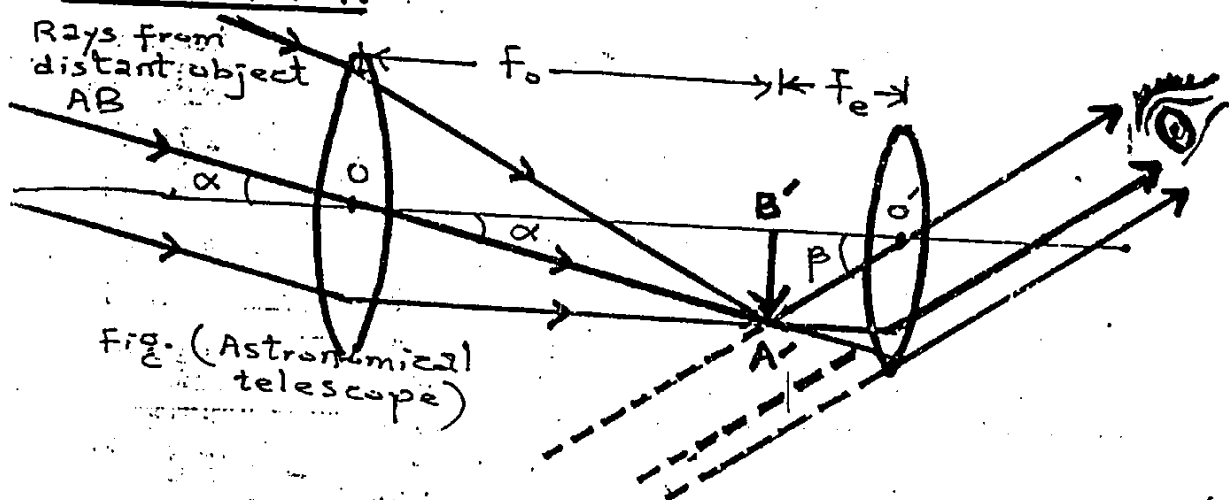

Fig. (Astronomical telescope)

WORKING.

The objective forms a real, inverted and diminished image $A'B'$ of a distant object AB . This real image $A'B'$ acts as object for the eyepiece which is used as a magnifying glass. The final image seen through the eyepiece is virtual, enlarge and inverted.

When the image $A'B'$ formed by the objective lies at the focus of eyepiece, the rays after refraction through the eyepiece becomes parallel and the final image appears to be formed at infinity. In this condition the image $A'B'$ formed by the objective lies at the focus of both the objective and the eyepiece and the telescope is said to be in normal adjustment.

LENGTH OF TELESCOPE.

"The distance between the objective and eyepiece of a telescope in normal adjustment is called the length of the telescope." Hence;

$$L = f_o + f_e \quad \text{--- (1)}$$

MAGNIFYING POWER.

The angle ' α ' subtended at the unaided eye is practically the same as subtended at the objective and is equal to $\angle A'OB'$. Thus from the $\Delta OA'B'$,

$$\alpha \approx \tan \alpha = \frac{A'B'}{OB'} = \frac{A'B'}{f_o} \quad \text{--- (2)}$$

where $OB' = f_o =$ focal length of the objective.

Similarly, the angle ' β ' subtended at the eye by the final image is equal to $\angle A'O'B'$. Thus from another $\Delta A'O'B'$,

$$\beta \approx \tan \beta = \frac{A'B'}{O'B'} = \frac{A'B'}{f_e} \quad \text{--- (3)}$$

where $O'B' = f_e =$ focal length of eyepiece.

As Magnification power of telescope is

$$M = \frac{\beta}{\alpha} \quad \text{--- (A)}$$

$$\therefore M = \frac{A'B'/f_e}{A'B'/f_o} = \frac{f_o}{f_e} = \frac{\text{Focal length of the objective}}{\text{Focal length of the eyepiece}}$$

i.e., Magnifying power of a telescope can be increased to some extent by using objective of greater focal length and eyepiece of smaller focal length.

Besides having a high magnifying power, a problem occurs which confronts the astronomers while designing a telescope to see the distant planets and stars is that they would like to gather as much light from the object as possible. This difficulty is overcome by using the objective of large aperture so that it collects a greater amount of light from the astronomical objects. Thus a good telescope has an objective of long focal length and large aperture.

DRAW BACK.

In astronomical telescope final image is inverted. It makes no difference when we are observing a spherical distant object or a planet but when we are observing a distant object on ground, then inverted image is not desirable.

REFLECTING TELESCOPE:

Large astronomical telescope are reflecting type made from specially shaped very large mirrors used as objectives. With such telescopes, astronomers can study stars which are millions light year away.

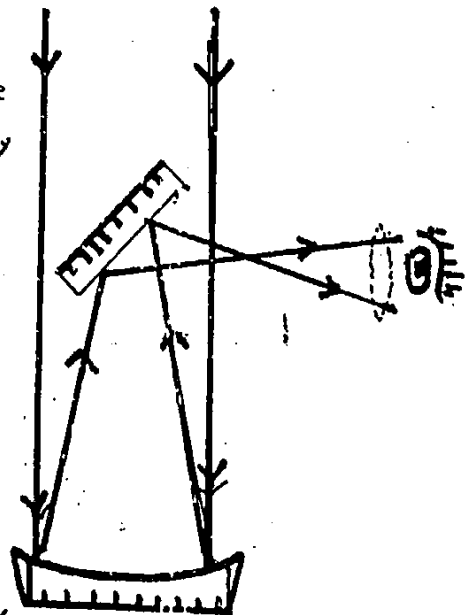

Fig. (Reflecting telescope)
(R.T.)

10.6 SPECTROMETER:

Def — "An optical instrument used to study the spectra from different sources of light is known as spectrometer."

USES OF SPECTROMETER.

- 1 — It is used to determine the refractive index of transparent material and the deviation of light by a glass prism.
- 2 — It is used to study the spectra from different sources of light.
- 3 — By using diffraction gratings the spectrometer is used for the determination of wavelength of light.

CONSTRUCTION.

It consists of three main parts, which are

- (a) Collimator
- (b) Turn table
- (c) Telescope.

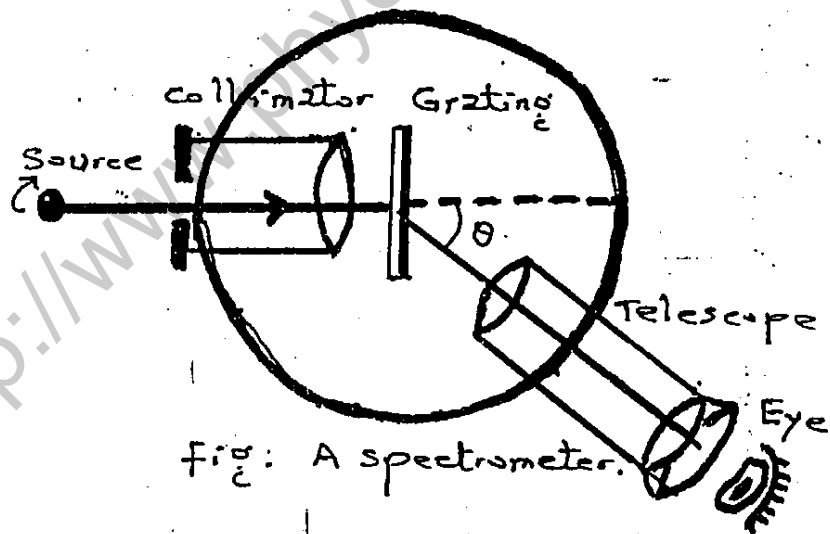

(a) COLLIMATOR.

A collimator is used to make the rays parallel. It consists of a fixed metallic tube with a convex lens at one end and an adjustable slit, that can slide in and out of the tube, at the other end. When the slit is just at the focus of the convex lens, the rays of light coming out of the lens become parallel. For this reason, it is called a collimator.

(P.T.O)

(b) TURN TABLE.

A turntable is used to support the instrument like prism or diffraction grating used to obtain spectra. It can be raised or lowered and can also be rotated about a vertical axis through any desired angle. This is provided with three leveling screws. A circular scale, graduated in half degrees, is attached with it.

(c) TELESCOPE.

The telescope is an ordinary telescope fitted with cross wire at the focal plane of the objective. The telescope can be rotated about the same vertical axis as the turntable. The movement of the telescope can be read on a circular scale graduated in degrees with the help of a vernier arrangement.

ADJUSTMENT.

In order to take observations.

Collimator is so adjusted in such a way that parallel rays of light emerge out of its convex lens. The telescope is adjusted in such a way that the rays of light entering it are focussed at the cross wires near the eyepiece. Finally, the refracting edge of the prism must be parallel to the axis of rotation of the telescope so that the turntable is levelled. This can be done using the leveling screws.

10.7 SPEED OF LIGHT:

INTRODUCTION.

Light travels so rapidly that it is very difficult to measure the speed. Galileo was the first person to make an attempt to measure the speed. Although he did not succeed, yet he was convinced that light does take some time to travel from one place to another.

MICHELSON'S EXPERIMENT.

Speed of light can be determined by Michelson's rotational mirror method.

CONSTRUCTION.

An eight sided polished mirror 'M' is mounted on the shaft of a motor whose velocity can be varied. The mirror 'm' is a plane mirror and 'T' is telescope. The mirror 'm' is placed at a distance 'd' from the mirror 'M'.

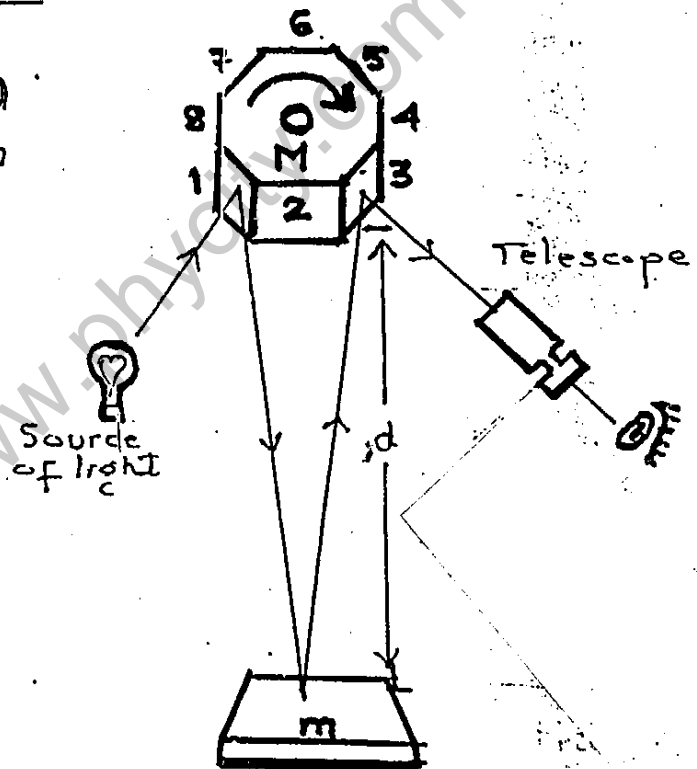

fig. Michelson's method for measurement of speed of light.

WORKING.

Suppose the mirror 'M' is stationary in the position shown in fig. A beam of light from source falls at some angle on face 1 of the mirror 'M'. After reflection from mirror 'M', light falls on mirror 'm'. Again reflection takes place from mirror 'm' and the reflected beam falls on face 3. On reflection from face 3, it enters the telescope 'T'.

(P.T.O.)

If the mirror 'M' is rotated clockwise, initially the source will not be visible through the telescope. When the mirror 'M' gains a certain speed, the source 'S' becomes visible. This happens when the time taken by light in moving from 'M' to 'm' and back to 'M' is equal to the time taken by face 2 to move to the position of face 3. Under this condition the light covers a distance of $2d$.

DERIVATION TO FIND THE SPEED OF LIGHT.

The angle subtended by any side of the eight sided mirror at the centre is $\frac{2\pi}{8}$. If the frequency of the mirror 'M' is 'f' when the source 'S' becomes visible. Then;

$$\text{Time taken by the mirror to rotate through an angle } 2\pi \text{ (time to complete one rev.)} = t = \frac{1}{f} \quad \text{--- (1)}$$

So the time taken by the mirror

$$\text{'M' to rotate through an angle } \frac{2\pi}{8} \text{ (because of its eight sides)} = t = \frac{1}{2\pi f} \times \frac{2\pi}{8} \quad \text{--- (2)}$$

$\because \theta = \omega t$
 $t = \frac{\theta}{\omega}$
 $t = \frac{1}{2\pi f} \times \frac{2\pi}{8}$
 and $\omega = 2\pi f$

The time taken by the light for its passage from 'M' to 'm' and then back, where 'c' is the speed of light.

$$= t = \frac{2d}{c} \quad \text{--- (3)} \quad \because s = vt \text{ or } t = \frac{s}{v}$$

These two times are equal so;

$$\frac{1}{8f} = \frac{2d}{c}$$

$$\text{or } \boxed{c = 16fd} \quad \text{--- (4)}$$

This eq. was used to determine the speed of light by Michelson.

(P.T.O)

Presently accepted value for the speed of light in vacuum is

$$c = 2.99792458 \times 10^8 \text{ m s}^{-1}$$

On rounding off ;

$$c = 3.00 \times 10^8 \text{ m s}^{-1}$$

The speed of light in other materials is always less than 'c'. In media other than vacuum, it depends upon the nature of the medium. However, the speed of light in air is approx. equal to that in vacuum.

10.8 INTRODUCTION TO FIBRE OPTICS: (OPTICAL COMMUNICATION AND PROBLEMS): HISTORICAL DEVELOPMENT.

Since ancient times, man has needed to communicate with others. Pre-historic man made sounds by beating hollow logs with heavy sticks to communicate messages to others. Reed pipes were also used for the same purpose. Smoke or fire signals were also used for the communication purposes. Man used flashes of reflected sunlight by day and lanterns by night. In the earliest civilizations, various combinations of torches on high mountain peaks were used to communicate rapidly over considerable distances. Navy signalmen still use powerful blinker lights to transmit coded messages to other ships during periods of radio silence. The use of visible optical carrier waves or light for communication has been common for many years.

It is an interesting but little known fact that Alexander Graham Bell in early 1880 invented a device known

as photo phone. (Just four years after the invention of the telephone). Bell's photo phone used a modulated beam of reflected sunlight, focussed upon a selenium detector several hundred metres away. With this device, Bell was able to transmit a voice message via a beam of light.

The transmission of light via a dielectric wave guide structure was first proposed and investigated at the beginning of the twentieth century. In 1910 Hondros and Debye conducted a theoretical study, and experimental work was reported by Schriever in 1920. However, a transparent dielectric rod, typically of silica glass with a refractive index of around 1.5, surrounded by air, proved to be an impractical waveguide due to its supported structure and the excessive losses at any discontinuities of glass-air interface. Then after many researches we have got a structure shown in fig which shows a transparent core with refractive index ' n_1 ' surrounded by a transparent cladding of slightly

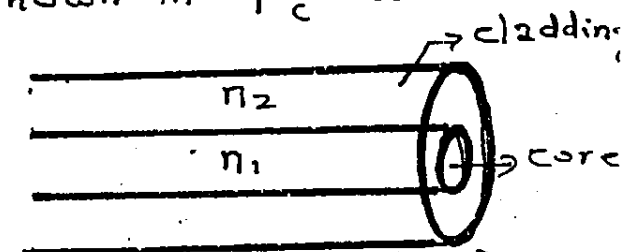

fig (optical fibre)

lower refractive index ' n_2 '. Due to cladding, the waveguide structure gets support and there is a considerable reducing in the radiation loss. This was first proposed by Charles H Kao and George A Hockman in 1966, to utilize optical fibre in communication. Then, later on, the progress in glass refining, processes such as depositing vapour-phase reagents to form

(P.T.O)

silica has allowed fibres with losses below dB/km to be fabricated. Ultimately, a fibre was formed through which thousands of signals were transmitted simultaneously with an extremely high speed from one part of the world to the other. Such glass fibre is known as Optical fibre.

10.9 FIBRE OPTIC PRINCIPLES:

Propagation of light in an optical fibre requires that the light should be totally confined within the fibre. This may be done in two different way;

- 1 — Total internal reflection
- 2 — Continuous refraction.

① TOTAL INTERNAL REFLECTION.

When light enters from a denser medium to a rarer medium, then it bends away to the normal. In such cases, the angle of refraction is always greater than angle of incidence. If we increase the angle of incidence then angle of refraction will also increase until at some angle of incidence, the angle of refraction becomes 90° . So, the angle of incidence for which the angle of refraction is 90° is called critical angle denoted by θ_c .

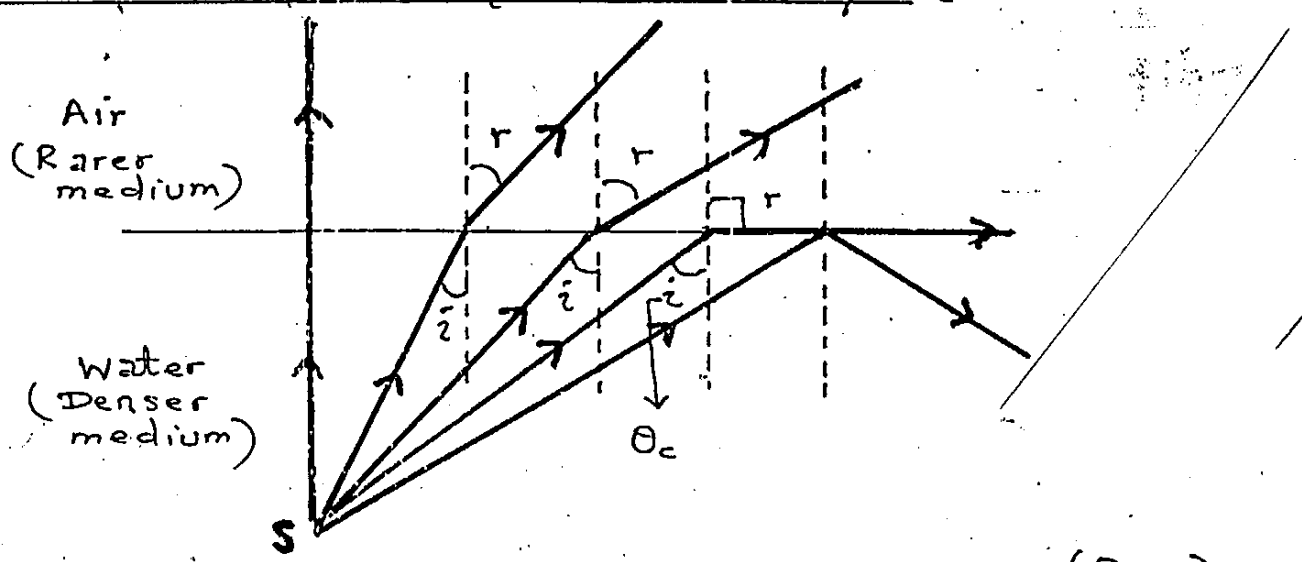

(P.T.O)

When in a denser medium the angle of incidence becomes greater than critical angle, then light did not refract but reflection takes place from the boundary of two media as shown in fig. Such phenomenon of light is known as total internal reflection.

One of the quality of any optically transparent material is the speed at which light travels within the material i.e; it depends upon the refractive index ' n ' of the material. The index of refraction is merely the ratio of the speed of light ' c ' in vacuum to the speed of light ' v ' in that material.

Mathematically,

$$n = \frac{c}{v} \quad \text{--- (1)}$$

The boundary between two optical media, e.g; glass and air having different refractive indices can reflect or refract light rays. The amount and direction of reflection or refraction is determined by;

- the amount of difference in refractive indices
- the angle at which the rays strike the boundary.

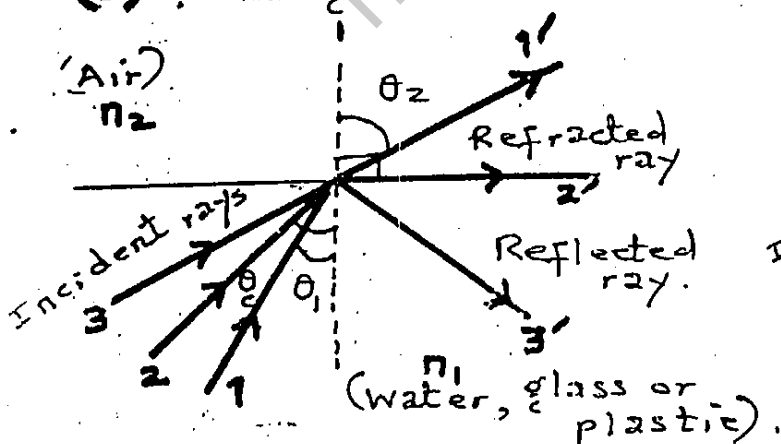

Fig(a) If the angle of refraction in the air is 90° , the angle of incidence is called the critical angle.

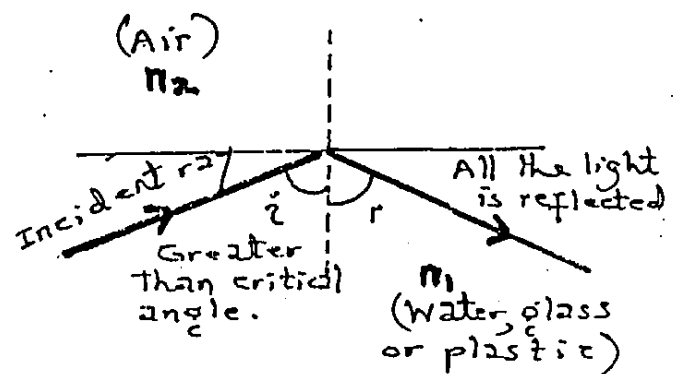

Fig(b) For angles of incidence greater than the critical angle, all the light is reflected; none is refracted into the air.

From fig (a) As Snell's law is

$$n_1 \sin \theta_1 = n_2 \sin \theta_2 \quad \text{--- (2)}$$

When $\theta_1 = \theta_c$, $\theta_2 = 90^\circ$

Thus $n_1 \sin \theta_c = n_2$

or, $\sin \theta_c = n_2 / n_1 \quad \text{--- (3)}$

From fig (b). For incident angles equal to or greater than the critical angle, the glass-air boundary will act as a mirror and no light escapes from the glass. For glass-air boundary, we have

$$\sin \theta_c = \frac{n_2}{n_1} = \frac{1.0}{1.5}$$

or $\theta_c = 41.8^\circ \quad \text{--- (4)}$

From fig (c). Let us now assume that the glass is formed into a long round rod. We know that all the light rays striking the internal surface of the glass at angles greater than 41.8° (critical angle) will be reflected back into the glass, while those with angles less than 41.8° will escape from the glass. **Ray 1** is injected into the rod so that it strikes the glass-air boundary at about 30° . Since

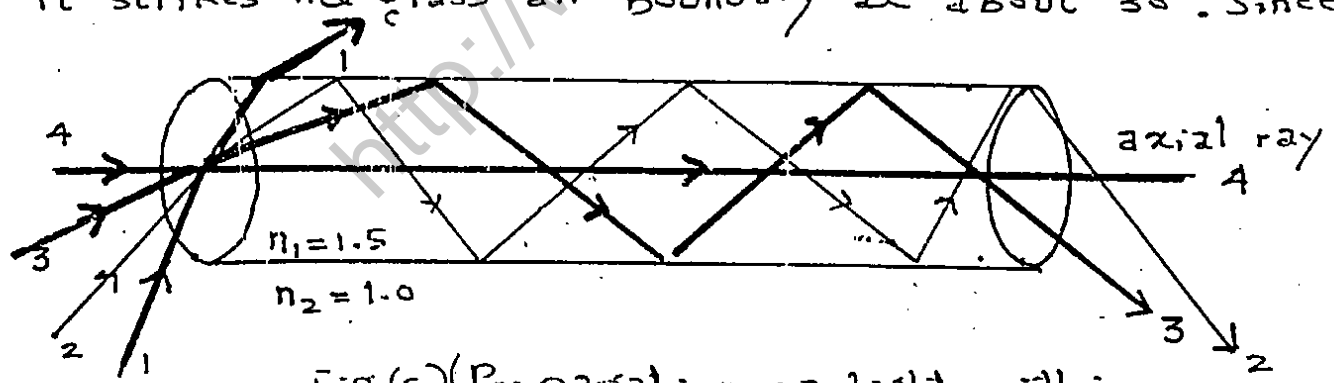

fig (c) (Propagation of light within a glass rod.)

this is less than the critical angle, it will escape from the rod and be lost. **Ray 2** at 42° will be reflected back into the rod, as will **ray 3** at 60° . Since the angle of reflection equals the angle of incidence, these two rays will continue to propagate

(P.T.O)

down the rod, along paths determined by the original angles of incidence. Ray 4 is called an axial ray since its path is parallel to the axis of the rod. Axial rays will travel directly down this straight and rigid rod.

From fig (d),

However, in a flexible glass fibre they will be subjected to the laws of reflection

optical fibres that propagate light

by total internal reflection are the most widely used.

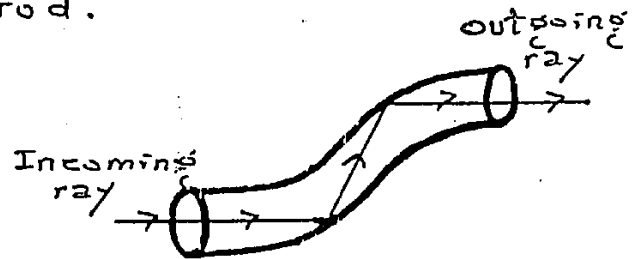

fig (d) Light propagation within a flexible glass fibre.

② CONTINUOUS REFRACTION.

There is another mode of propagation of light through optical fibres, in which light is continuously refracted through the fibre. For this purpose

1. central core has high refractive index (high density) and over it is a layer of a lower refractive index (less density).

This layer is called cladding. Such a type of fibre is called multimode index fibre whose cross section view is shown in fig (e).

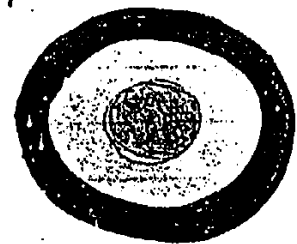

fig (e) cross sectional view of multimode step index fibre.

2. Now a days, a new type of optical fibre is used in which the central core has high refractive index (high density) and its density gradually decreases towards its periphery. The type of fibre is called a multi-mode graded index fibre as shown cross section view in fig (f).

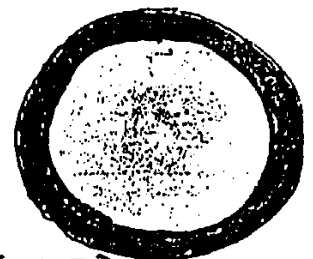

fig (f) Cross sectional view of multi mode graded index fibre.

EXPLANATION-

24-10

In both these fibres the propagation of light signal is through continuous refraction.

As a ray passing from a denser medium to a rarer medium bends away from the normal and vice versa. In step index or graded

index fibre, a ray of light entering the optical fibre as shown in fig (g), is continuously refracted through these steps and is reflected from the surface of the outer layer. Hence light is transmitted by continuous refraction and total internal reflection.



fig (g) Light propagation within a hypothetical multi layer fibre.

STRUCTURE OF OPTICAL FIBRE.

In Optical fibre, information is transmitted in the form of light. Optical fibre consists of two parts:

- 1 — Core
- 2 — cladding.

The central portion of the optical fibre is called core. Core is wrapped by cladding. Both are made of

Silica SiO_2 . The refractive index of the core is slightly greater than that of cladding. Core and cladding is covered by a jacket. The diameter of the core usually ranges from $5\mu m$ to $50\mu m$.

The refractive index of the core is increased by the doping of Germanium. However the refractive index of the cladding can be minimized by the doping of Boron.

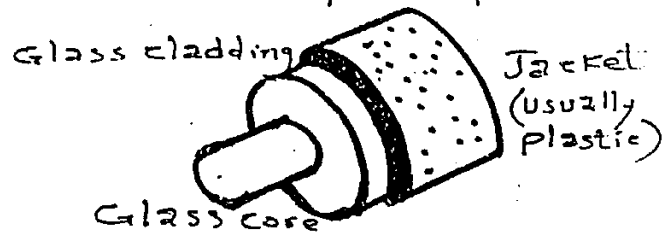

fig

-(P.T.O)

10.10 TYPES OF OPTICAL FIBRES :

There are three types of optical fibres which are grouped by the way they propagate light. These are:

- 1— Single mode step index fibre
- 2— Multimode step index fibre
- 3— Multimode graded index fibre.

MODE .

“It is described as the method by which light is propagated within the fibre i.e; the various paths that light can take in travelling down the fibre.”

① SINGLE MODE STEP INDEX FIBRE.

Def — “It is the optical fibre with a core of constant refractive index n_1 and a cladding of a slightly lower refractive index n_2 is known as step index fibre.”

Single mode or mono mode step index fibre has a very thin core of about $5\mu\text{m}$ diameter and has a relatively larger cladding (of glass or plastic) as shown in fig (a) and (b).

Since it has a very thin core, a strong monochromatic light source (i.e; a laser source) has to

be used to send light signals through it. It can carry more than 14 TV channels or 14,000 phone calls. Only one signal can propagate in this fibre.

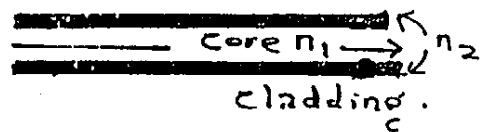
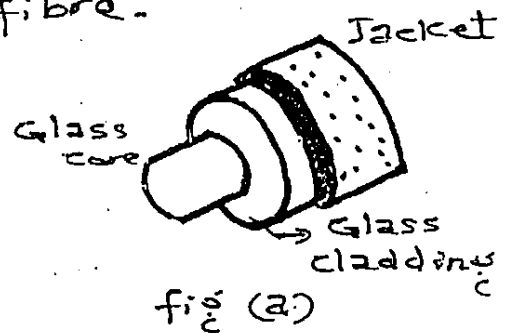

fig (b)

② MULTIMODE STEP INDEX FIBRE.

Def — “It is the fibre with a core of relatively larger diameter of around $50\mu\text{m}$ or greater, which is large enough to allow the propagation of many modes within the fibre core.”

It is mostly used for carrying white light but due to dispersion effects, it is useful for a short distance only. The fibre core has a constant refractive index ' n_1 ', such as 1.52, from its centre to the boundary with the cladding as shown in fig (c). The refractive index then changes to a lower value ' n_2 ', such as 1.48, which remains constant throughout the cladding.

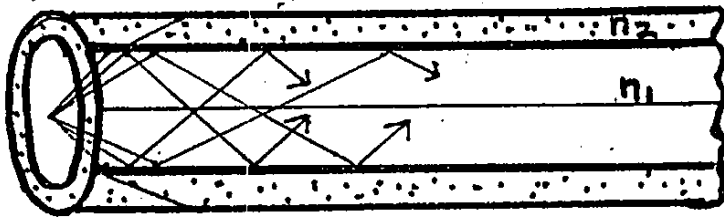

fig. (c) Light propagation through Multimode step index fibre.

This is called a step index multimode fibre, because the refractive index steps down from 1.52 to 1.48 at the boundary with the cladding.

③ MULTIMODE GRADED INDEX FIBRE.

Def — "It is the fibre which has a variable refractive index in the core is called multimode graded index fibre."

It has a range in diameter from 50 to 1000 μm . It has a core of relatively high refractive index and the refractive index decreases gradually from the middle to the outer surface of the fibre. There is no noticeable boundary between core and cladding. This type of fibre is called the multimode graded index fibre as shown in fig (d).

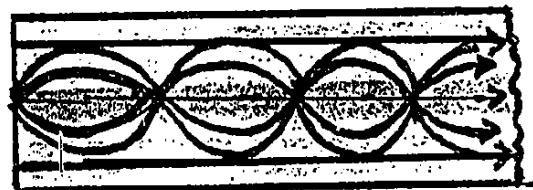

fig (d) Light propagation through multimode graded index fibre.

It is very useful for long distance applications in which white light is used.

Due to continuous refraction from the surface of

smoothly decreasing refractive index or due to total internal reflection from the boundary of the outer surface the mode of transmission of light remains same through this type of fibre.

EXAMPLE 10.2: Calculate the critical angle and angle of entry for an optical fibre having core of refractive index 1.5 and cladding of refractive index 1.48.

DATA. Refractive index of core = 1.5
 Refractive index of cladding = 1.48
 Critical angle = $\theta_c = ?$
 Angle of entry of light = $\theta = ?$

Sol.

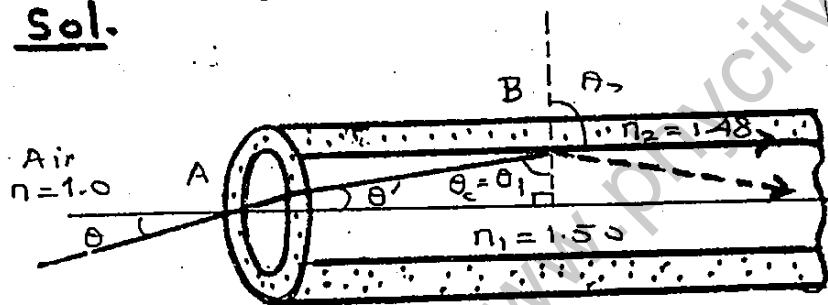

Fig:

According to Snell's law

$$n_1 \sin \theta_1 = n_2 \sin \theta_2 \quad \text{--- (1)}$$

when $\theta_1 = \theta_c$ and $\theta_2 = 90^\circ$

$$\text{So, } 1.5 \sin \theta_c = 1.48 \sin 90^\circ$$

$$\sin \theta_c = \frac{1.48 \times 1}{1.5} = 0.987$$

$$\theta_c = \sin^{-1}(0.987) = \boxed{80.6^\circ}$$

From fig, $\theta' = 90^\circ - \theta_c$

$$\theta' = 90^\circ - 80.6^\circ = 9.4^\circ \quad \text{--- (2)}$$

Again using Snell's law,

$$n_1 \sin \theta' = n \sin \theta \quad \text{--- (3)}$$

Putting the values, we have

$$1.5 \times \sin 9.4^\circ = 1 \times \sin \theta$$

$$\sin \theta = 1.5 \times 0.163 = 0.2445$$

$$\theta = \sin^{-1}(0.2445) = \boxed{14.2^\circ}$$

If light beam is incident at the end of the optical fibre at an angle $\theta > 14.2^\circ$, total internal reflection would not take place.

(P.T.O)

10.11 SIGNAL TRANSMISSION AND CONVERSION TO SOUND:

A fibre optic communication system consists of three major components:

- 1— A transmitter that converts electrical signal to light signal.
- 2— An optical fibre for guiding the signals.
- 3— A receiver that captures the light signals at the other end of the fibre and reconverts them to electric signals.

The light source in the transmitter can be either a semiconductor laser or a light emitting diode (LED). With either device, the light emitted is an invisible infra-red signals. The typical wavelength is $1.3 \mu\text{m}$. Such a light will travel much faster through optical fibres than will either visible or ultra-violet light. The lasers and LEDs used in this application are tiny units (less than half the size of the thumbnail) in order to match the size of the fibres. Usually digital modulation is used to transmit information by light waves whether it is an audio signal, a television signal or a computer data signal. In digital modulation unit, laser or LED is flashed on and off at an extremely fast rate. A pulse of light represents the number 1 and the absence of light represent zero. In a sense, instead of flashes of light travelling down the fibre, ones (1s) and zeros (0s) are moving down the path.

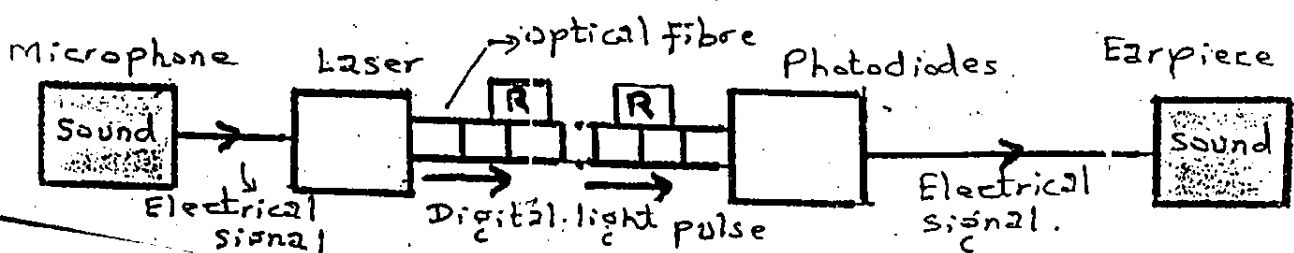

Fig. C

The receiver is programmed to decode the 1s and 0s, it receives, into sound, pictures or data as required. Digital modulation is expressed in bits (binary digit) or mega bits (10^6 bits) per second, where a bit is a 1 or a 0.

Despite the ultra purity (99.99% glass) of the optical fibre, the light signals eventually become dim by absorption and scattering, so, amplifiers called repeaters (R) are used. Repeaters are typically placed about 30 km apart, but in the newer systems they may be separated by as much as 100 km.

At the end of the fibre, a photodiode converts the light signals, which are then amplified and decoded, if necessary, to reconstruct the signals originally transmitted.

10.12 LOSSES OF POWER:

1 — By Scattering and absorption.

When a light signal travels along fibres by multiple reflection, some light is absorbed due to impurities in the glass. Some of it is scattered by groups of atoms which are formed at places such as joints when fibres are joined together. Careful manufacturing can reduce the power loss by scattering and absorption.

2 — Spreading or dispersion.

The information received at the other end of a fibre can be inaccurate due to dispersion or spreading of the light signal. Also the light signal may not be perfectly monochromatic. In such cases, a narrow band of wavelengths are refracted in different directions when the light signal enters

(P.T.O)

The receiver is programmed to decode the 1s and 0s, it receives, into sound, pictures or data as required. Digital modulation is expressed in bits (binary digit) or mega bits (10^6 bits) per second, where a bit is a 1 or a 0.

Despite the ultra purity (99.99% glass) of the optical fibre, the light signals eventually become dim by absorption and scattering, so, amplifiers called repeaters (R) are used. Repeaters are typically placed about 30 km apart, but in the newer systems they may be separated by as much as 100 km.

At the end of the fibre, a photodiode converts the light signals, which are then amplified and decoded, if necessary, to reconstruct the signals originally transmitted.

10.12 LOSSES OF POWER:

1 — By Scattering and absorption.

When a light signal travels along fibres by multiple reflection, some light is absorbed due to impurities in the glass. Some of it is scattered by groups of atoms which are formed at places such as joints when fibres are joined together. Careful manufacturing can reduce the power loss by scattering and absorption.

2 — Spreading or dispersion.

The information received at the other end of a fibre can be inaccurate due to dispersion or spreading of the light signal. Also the light signal may not be perfectly monochromatic. In such cases, a narrow band of wavelengths are refracted in different directions when the light signal enters

(P.T.O)

the glass fibre and the light spreads.

Fig (a) shows the paths of light of three different wavelengths λ_1 , λ_2 and λ_3 . λ_1 meets the core-cladding at the critical angle and λ_2 and λ_3 at slightly greater angles. All the rays travel along the fibre by multiple reflections, But the light paths have different lengths.

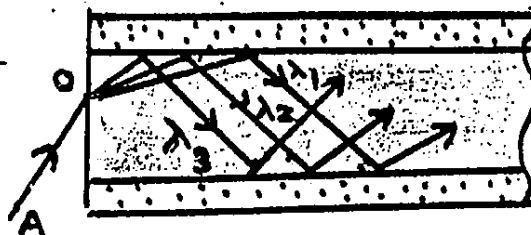

Fig (a) Light paths in step index fibre.

So the light of different wavelengths reaches the other end of the fibre at different times. The signal received is, therefore, faulty or distorted.

3— Fibre bend Loss.

Optical fibres suffer radiation losses at bends or curves on their paths. This is due to energy in the evanescent field, as the bend exceeding the velocity of light in the cladding. Hence, the guidance mechanism is habited, which causes light energy to be radiated from the fibre.

4— Disadvantage of the step index fibre.

The disadvantage of the step index fibre fig (a) can considerably be reduced by using a graded index fibre as shown in fig (b), the different wavelengths still take different paths and are totally internally reflected at different layers, but still they are focussed at the same point like 'X' and 'Y' etc. It is possible because the speed is inversely proportional to the refractive index. So the wavelength λ_1 travels a longer path than λ_2 or λ_3 but at a greater speed.



Fig (b) Light paths in graded index fibre.

In spite of the different dispersion,

all the wavelengths arrive at the other end of the fibre at the same time. With a step-index fibre, the overall time difference may be about 33 ns per km length of fibre. Using a graded index fibre, the time difference is reduced to about 1 ns per km.

ADVANTAGES AND DISADVANTAGES OF OPTICAL FIBRE.

① ADVANTAGES OF OPTICAL FIBRE.

The use of light as a transmission carrier wave in fibre optics has several advantages over radio wave or even to conventional metallic wires.

1. High Bandwidth.

The information carrying capacity of a carrier wave called the bandwidth increases with carrier frequency. i.e; the optical carrier frequency yields a far greater potential transmission bandwidth than metallic cable systems or even millimeter wave radio systems. Optical fibres can have bandwidths of several GHz km allowing very high speed transfer of data. Several signals can be transmitted through one fibre. For example, a single fibre has the transmission capacity of a 900 pair copper cable.

2. Low Loss.

Optical fibre provide low attenuation than copper wires. The attenuation of an optical fibre is essentially independent of frequency whereas copper cables exhibit high losses as frequency increases. The lower loss of optical fibre allows the spacing between repeaters on long transmission lines to be extended, thereby reducing system

cost and complexity.

3 — Small size and Light Weight:

Optical fibres have very small diameters which are often not greater than the diameter of a human hair. Hence, even such fibres are covered with protective coatings. They are far smaller and much lighter than equivalent copper cable. An optical fibre with its protective case may be typical 6.0mm in diameter. It can replaced by 7.62cm diameter bundle of copper wires to carry the same amount of signals.

4 — Signal Security.

The light from optical fibres does not radiate significantly and therefore they provide a high degree of signal security. This feature is obviously attractive for military, banking and general data transmission applications.

5 — Immunity to Interference.

Optical fibres are fabricated from a dielectric material (glass) and are therefore free from electromagnetic and electromagnetic pulses arising from switching transients. Thus a fibre cable does not require any electrically noisy environments.

6 — Cross talk.

Being non inductive there is no induction of signal into/from other circuits so that possibility of cross talk is virtually eliminated.

7 — Abundance of Raw Material.

The manufacturing material of optical fibre is silica which is naturally available in its different combinations in sea sand, rocks in form of different chemical compositions of silica of different materials.

8 — Temperature / Loss characteristics.

The properties of conductors changes with temperature variations. The optical fibre is made of glass (silica) which has a melting point above 1000°C . So, at normal temperature the fibre transmission properties does not change, therefore, no additional measures are required in this regard.

9 — Transmission of Light.

It is also used to transmit the light around the corners even in those inaccessible places which are unobservable in normal conditions. Due to this property of transmission of light, optical fibre are also of a great importance in industry and in medical technology.

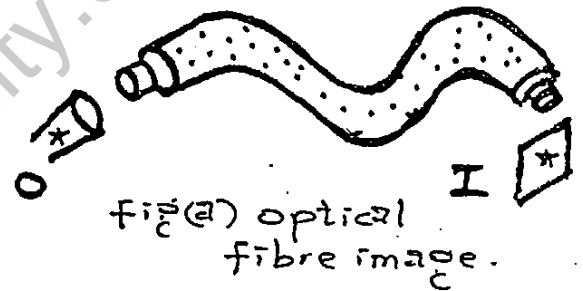

Fig. (b). A precision diamond scalpel for use in eye surgery. The illumination is obtained by light passing through a fibre optic light guide.

10 — Communication.

Recently, the optical fibre technology has evolved into something much more important and useful. It is the communication system of enormous capabilities.

Important features in communication are:

- (a) In telephone industry
- (b) Several television channels and numerous data signals between stations through one or two flexible, hair thin threads of optical fibre.

● DISADVANTAGES OF OPTICAL FIBRE.

The disadvantages of optical fibre are as follows.

1 — Cost.

Although the raw material of optical fibre is enough but manufacture of optical fibre is extremely difficult and involves complete set up for heat and chemical treatment of SiO_2 to reach the desired purity required to produce optical fibre.

2 — Mechanical problems.

Since optical fibre is fragile, it needs extra care in handling, special cabling and protection against contamination and high degree of precision for splicing.

3 — Hazards with Lasers.

Laser is transmitted through optical fibres. These radiations are extremely dangerous. Their exposure to eyes or skin can cause irreparable damage. Necessity of safety precautions must be taken while working with the optical fibre system.